

## Helicopters

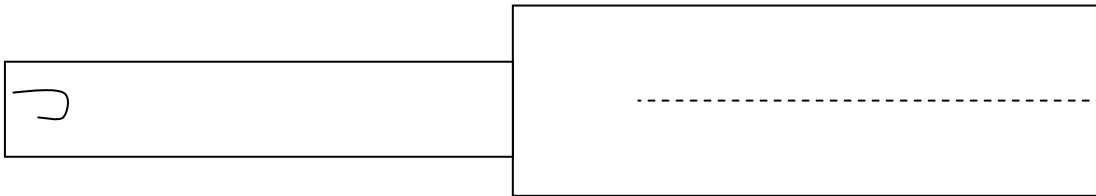

### 1. Building your helicopter

- Make a copy of the diagram below.
- Cut out the helicopter shape, and cut along the dotted line.
- Fold the wings out and add a paperclip as shown. Drop the helicopter from the highest point possible (the roof of your classroom is OK).

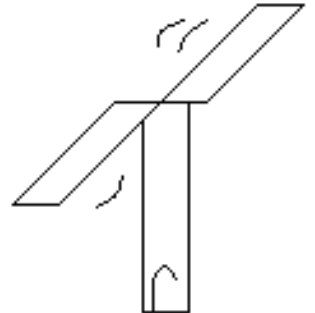

### 2. Estimating

You are going to estimate the speed of the helicopter.

- Estimate the height of the point from which you drop the helicopter.
- Judge the time it takes to fall from this point to the floor.
- Use this information to make a rough calculation of the helicopter's speed.

Use the following equation to calculate the speed:

$$\text{Speed (m/s)} = \frac{\text{Distance (m)}}{\text{Time (s)}}$$

Estimated height of fall \_\_\_\_\_ m

Estimated time of fall \_\_\_\_\_ s

Estimated speed \_\_\_\_\_ m/s

### 3. Measuring

- a. Measure the height of the fall as accurately as you can. What is the best instrument for this task?
- b. Use a stopwatch to measure the time it takes for the helicopter to fall. Repeat this until you have 10 good measurements. Ignore any that obviously went wrong.
- c. Calculate the speed of each fall, and work out the average speed.

### 4. Results

Test	1	2	3	4	5	6	7	8	9	10	Ave
Height (m)											
Time (s)											
Speed (m/s)											

### 5. Analysing

What was the average speed at which your helicopter fell?

---

How good were your results? (If your calculated speeds were all similar, your measurements were probably accurate).

---

---

### 5. Improvements

Drop the helicopter a few more times. Notice that it takes a short while to start spinning properly, and then it seems to fall at a constant speed. To make accurate measurements during your investigation, you should measure the speed only during this steady stage in the helicopters fall, and not during the first part.

How could you improve the method used above to take account of this accuracy problem?

---

---